

GROOVING CUTTERS FOR MANUAL FEED

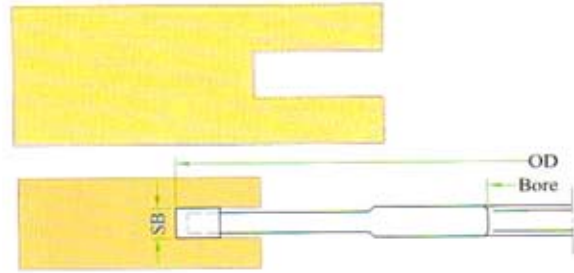

APPLICAION

For Making Grooves

MACHINE

Spinder Moulder
Double end Tenoner
Moulders

WORK PIECE MATERIAL

Solid Wood
Uncoted Veneered
Wood Derived Materials

BEVEL CUTTERS

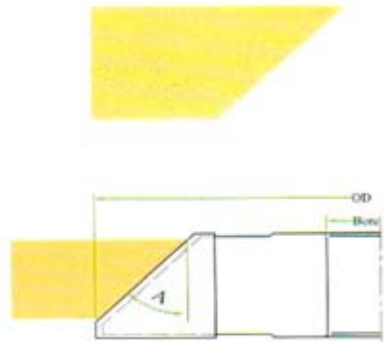

APPLICAION

For Making Bevel
on the Edges
of the work Piece.

MACHINE

Spinder Moulder
Double end Tenoner
Moulders

WORK PIECE MATERIAL

Solid Wood
Uncoted Veneered
Wood Derived Materials

RADIUS CUTTERS (CORNER TRIMMING)

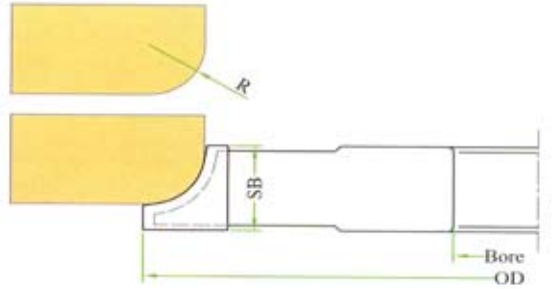
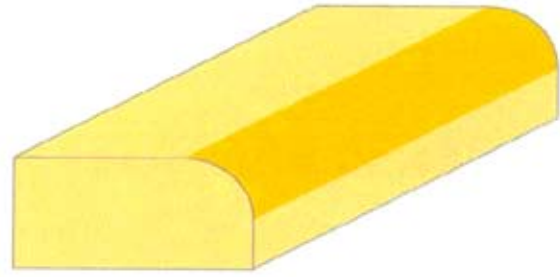

APPLICATION
For making Radius
at the corners of the
work piece.

MACHINE
Spindle Moulder,
Moulder

WORK PIECE MATERIAL
Solid Wood
Uncoated Wood
Derived materials.

FLUTING CUTTERS

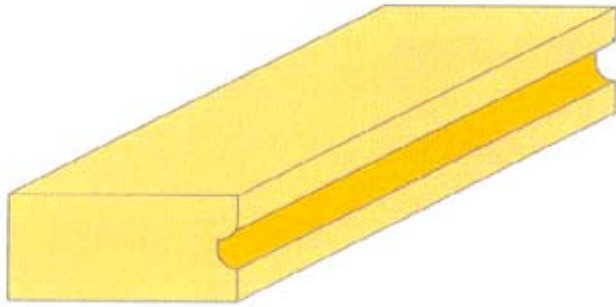

APPLICATION
For making Concave /
Convex Radius profiles
with single Cutter

MACHINE
Spindle Moulder
Moulder

WORK PIECE MATERIAL
Solid Wood
Uncoated Wood
Derived materials.

JOINTING CUTTERS (EDGE PLANING)

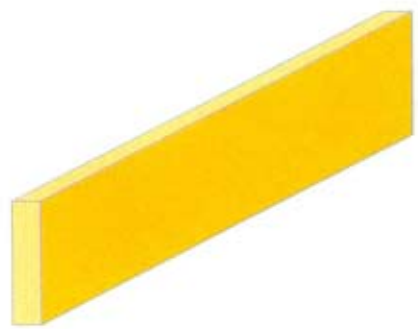

APPLICATION

For Pre Cutting, Jointing and Planing Operations.

MACHINE

Spindle Moulder, Moulder

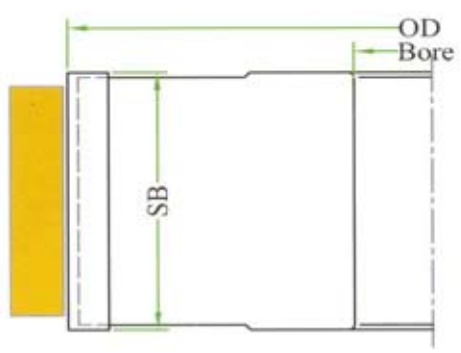

WORK PIECE MATERIAL

Solid Wood

COPY SHAPING CUTTERS FOR CURVED PROFILES

(Along with bearing)

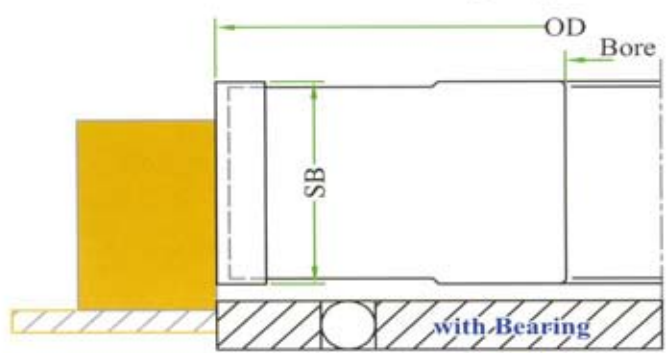

APPLICATION

For Pre Cutting, Jointing and Copy shaping curved work piece using Template ball bearing Planing Operations.

MACHINE

Spindle Moulder, Moulder

WORK PIECE MATERIAL

Solid Wood
Uncoated Wood
Derived materials.



BUTT JOINING CUTTERS

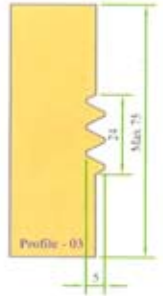
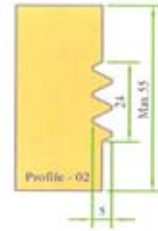
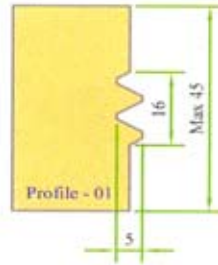
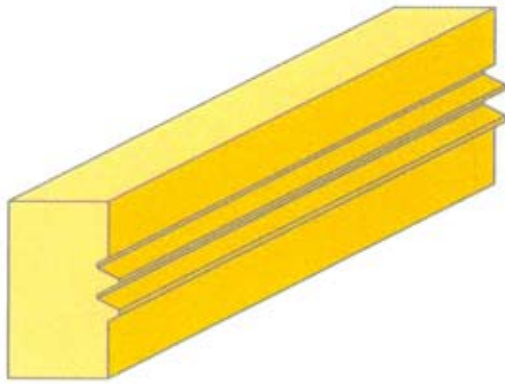

APPLICATION
To Cut Butt jointing profiles

MACHINE
Spindle Moulder,
Moulder

WORK PIECE MATERIAL
Solid Wood

GLUE JOINING CUTTERS

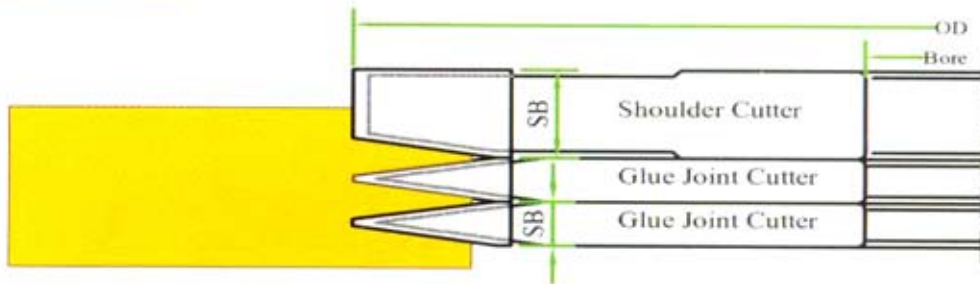

APPLICATION
To Cut glue jointing profile for joining

MACHINE
Spindle Moulder,
Moulder

WORK PIECE MATERIAL
Solid Wood

PROFILE CUTTERS FOR SAW MILL SEGMENT

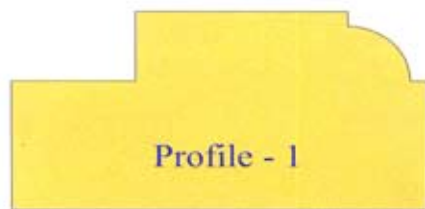
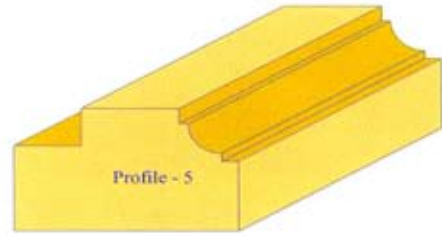
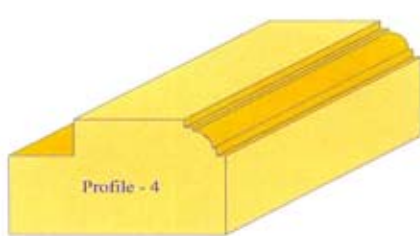

APPLICATION
Profile Cutters
used for making Choukhat.

MACHINE
Spindle Moulder,
Moulder

WORK PIECE MATERIAL
Solid Wood

BEADING PROFILE CUTTERS

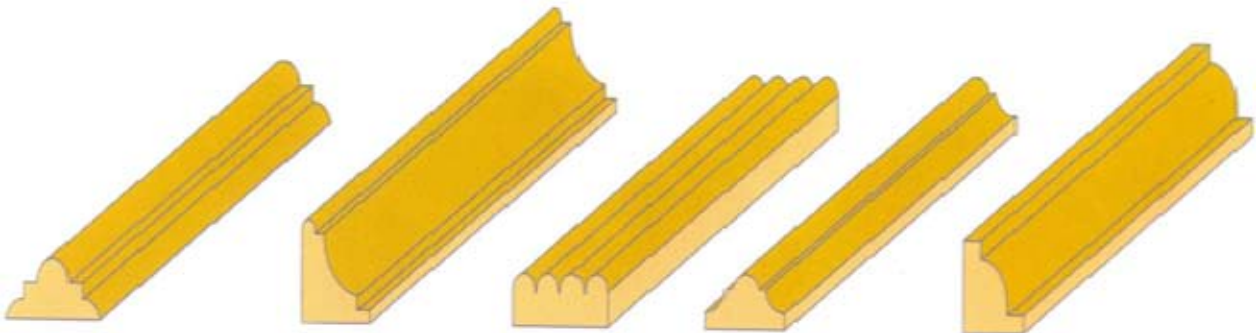

Profile - 01

Profile - 02

Profile - 03

Profile - 04

Profile - 05

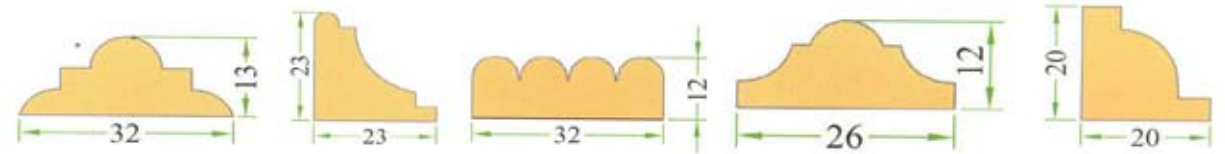

Profile - 01

Profile - 02

Profile - 03

Profile - 04

Profile - 05

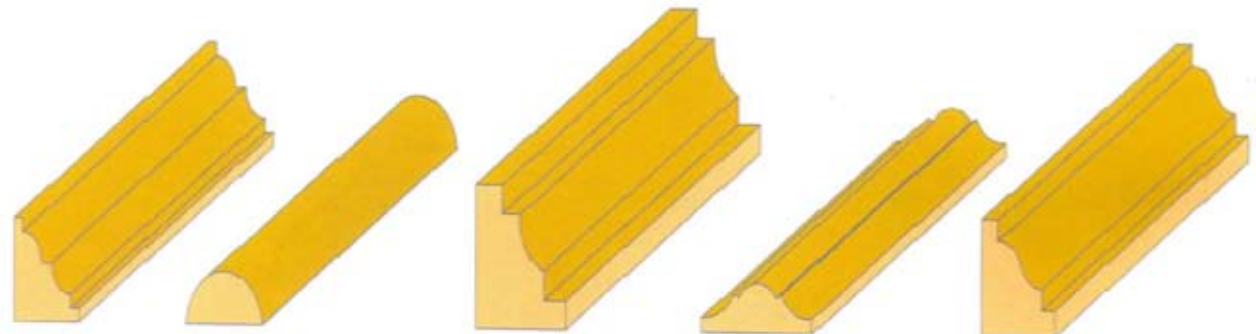

Profile - 06

Profile - 07

Profile - 08

Profile - 09

Profile - 10

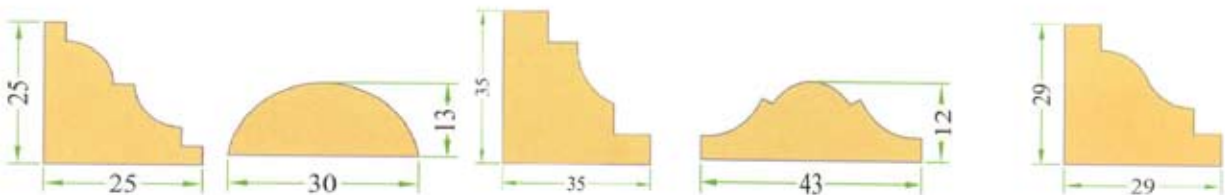

Profile - 06

Profile - 07

Profile - 08

Profile - 09

Profile - 10

APPLICATION
For making
Beading Profiles

MACHINE
Spindle Moulder,
Auto Moulder,

WORK PIECE MATERIAL
Solid Wood
Uncoated Wood
Derived materials.

STRAIGHT EDGE TRIMMING & GROOVING ROUTER CUTTER

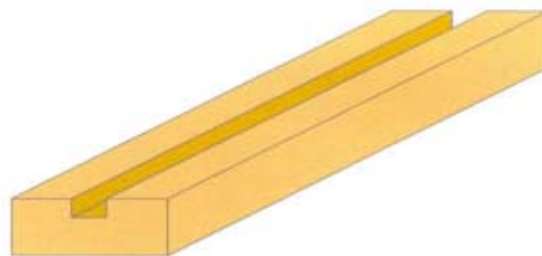
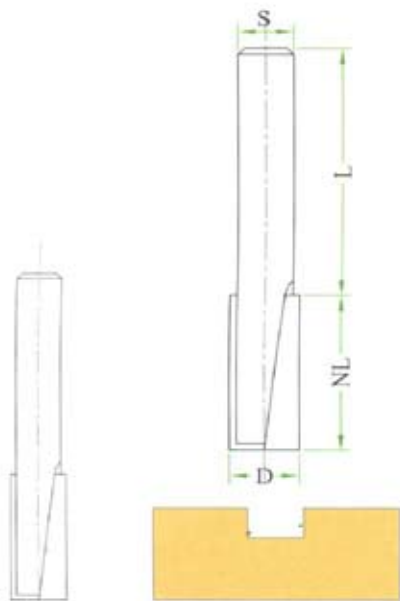

APPLICATION
For Grooving
Round Profiles

MACHINE
Overhead Routers
Portable Routers

WORK PIECE MATERIAL
Solid Wood
Uncoated Veneered
Wood Derived materials.

ROUNDNOSE ROUTER CUTTER

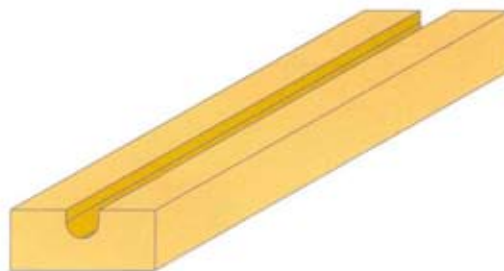

APPLICATION
For Grooving
Round Profiles

MACHINE
Overhead Routers
Portable Routers

WORK PIECE MATERIAL
Solid Wood
Uncoated Veneered
Wood Derived materials.

RADIUS PROFILE ROUTER CUTTER WITH BEARING

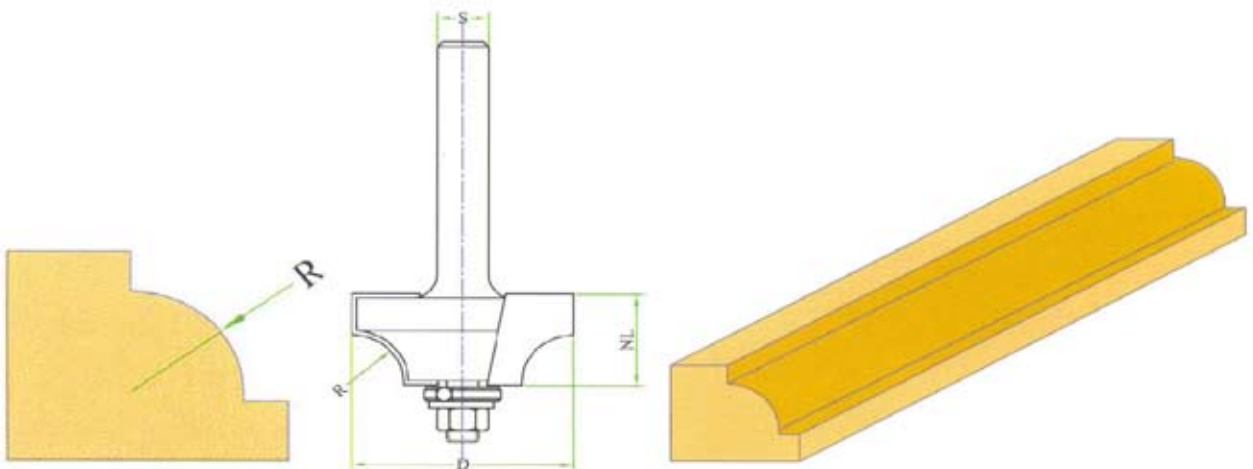

APPLICATION
For Edge Trimming
& Radius Profiles

MACHINE
Overhead Routers
with or without
CNC Control
Portable Routers

WORK PIECE MATERIAL
Solid Wood
Uncoated Veneered
Wood derived materials.

RADIUS PROFILE ROUTER CUTTER WITHOUT BEARING

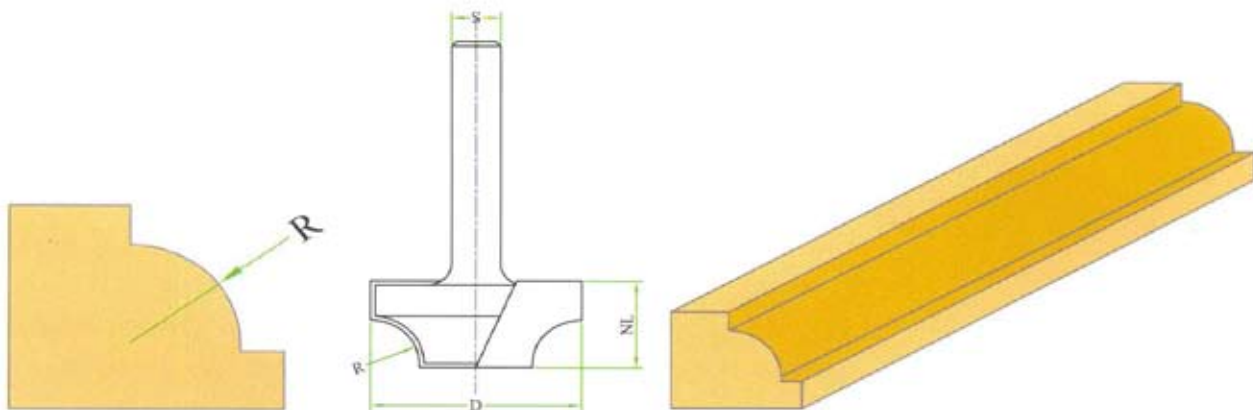

APPLICATION
For Edge Trimming
& Radius Profile

MACHINE
Overhead Routers
Portable Routers

WORK PIECE MATERIAL
Solid Wood
Uncoated Veneered
Wood derived materials.

BEVEL ROUTER CUTTER WITH BEARING

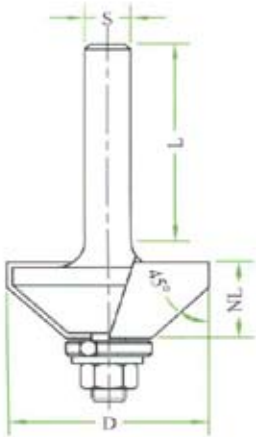

APPLICATION
For making
Bevel Profiles



MACHINE
Overhead Routers
with or without CNC Control
Portable Routers

WORK PIECE MATERIAL
Solid Wood
Uncoated Veneered
Wood Derived materials.



ANGULAR PROFILE ROUTER CUTTER WITH BEARING

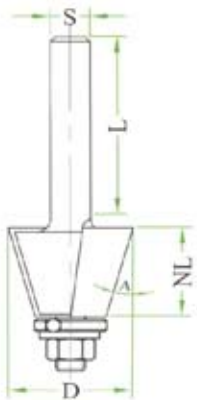

APPLICATION
For Angular Profiles

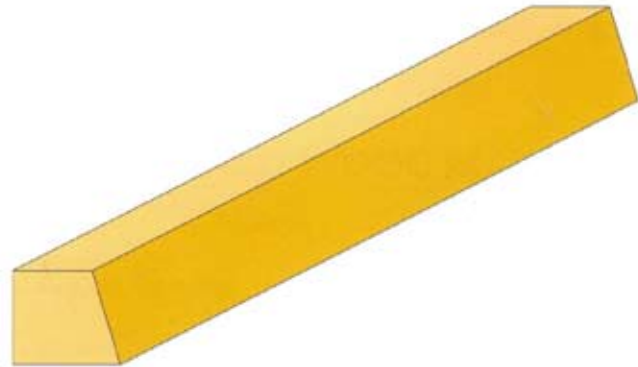

MACHINE
Overhead Routers
Portable Router

WORK PIECE MATERIAL
Solid Wood
Uncoated Veneered
Wood Derived materials.

FACE PROFILE ROUTER CUTTER

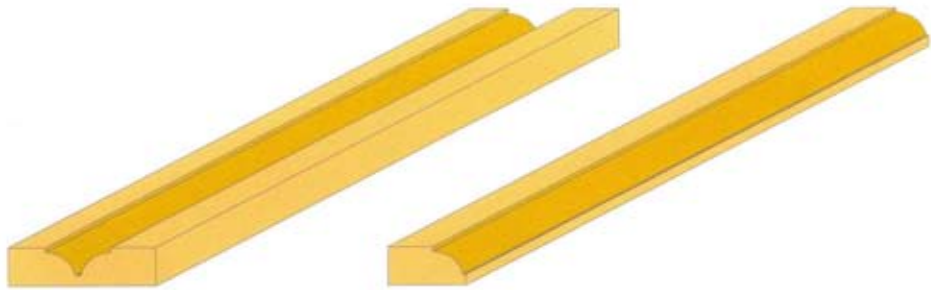
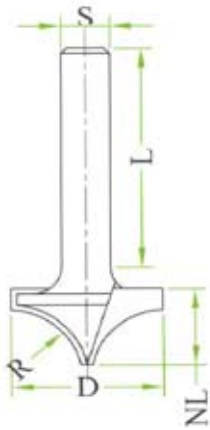

APPLICATION
For Face Profiling

MACHINE
Overhead Routers
Portable Routers

WORK PIECE MATERIAL
Solid Wood
Uncoated Veneered
Wood derived materials.

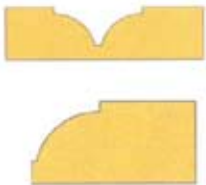

RADIUS ROUTER CUTTER



APPLICATION
For Profiling
MACHINE
Overhead Routers

WORK PIECE MATERIAL
Solid Wood
Uncoated Veneered
Wood Derived materials.

GROOVING CUTTERS FOR LAMELLO JOINTS

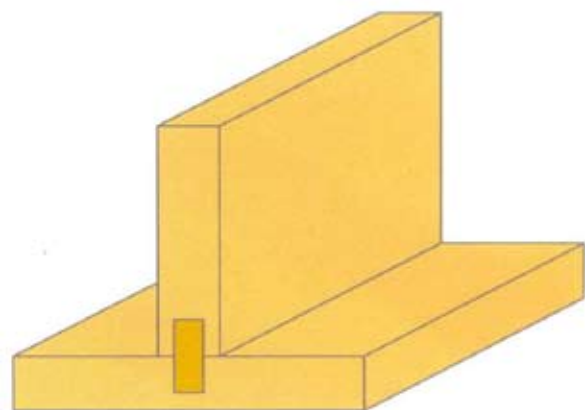
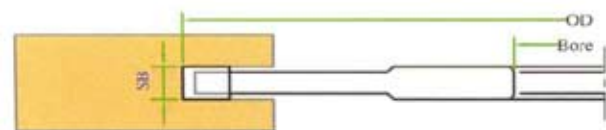

APPLICATION

For Cutting Grooves,
Corner Joints and
Longitudinal Joints,
Lamello Joints Etc.

MACHINE

Spindle Moulder
With or Without CNC Routers
Portable Power Tools

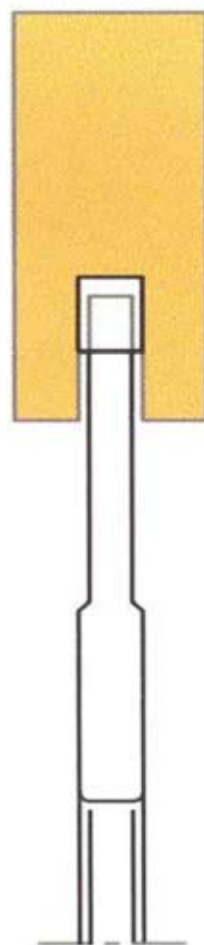

WORK PIECE MATERIAL

Solid Wood
Uncoated / Coated Veneered
Wood derived materials.

MULTI PURPOSE RADIUS / FLUTING CUTTERS

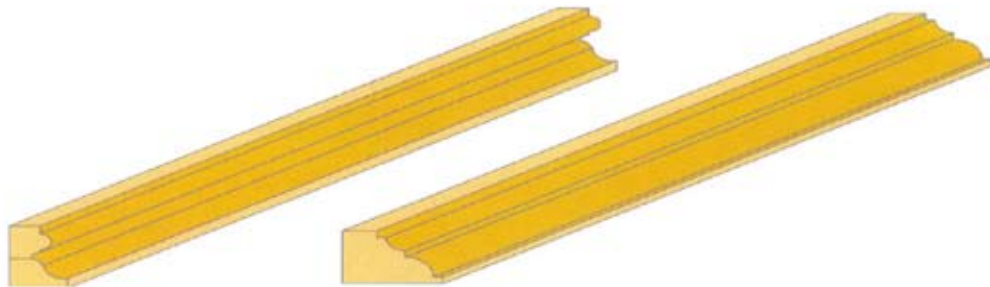

Option - 01

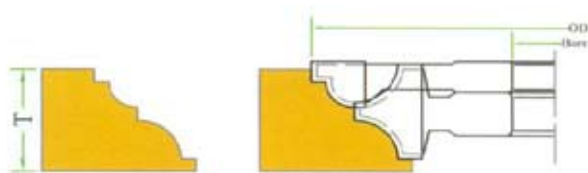

Option - 02

APPLICATION

For making Multi Radius with Single adjustable cutters

MACHINE

Spindle Moulder, Moulder

WORK PIECE MATERIAL

Solid Wood
Uncoated Wood
Derived materials.

PROFILE CUTTERS FOR HANDRAILS

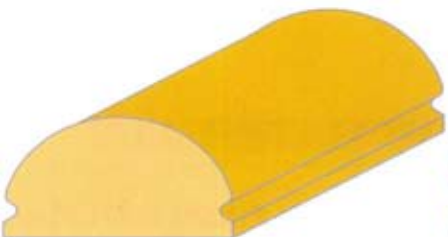

Profile - 01

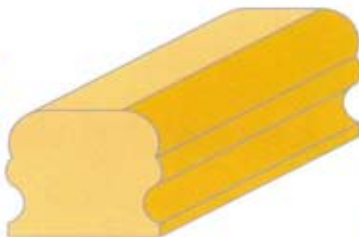

Profile - 02

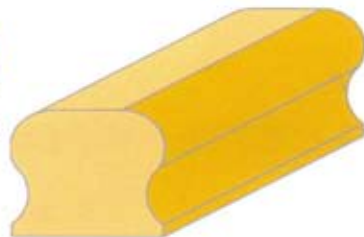

Profile - 03



PROFILE - 01



PROFILE - 02

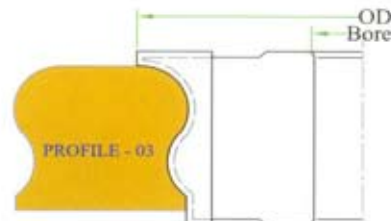

PROFILE - 03

APPLICATION

For making Handrail Profiles.

MACHINE

Spindle Moulder, Moulder, Double end Tenoner

WORK PIECE MATERIAL

Solid Wood
Uncoated Wood
Derived materials.

POST FORMING CUTTERS - QUARTER ROUND

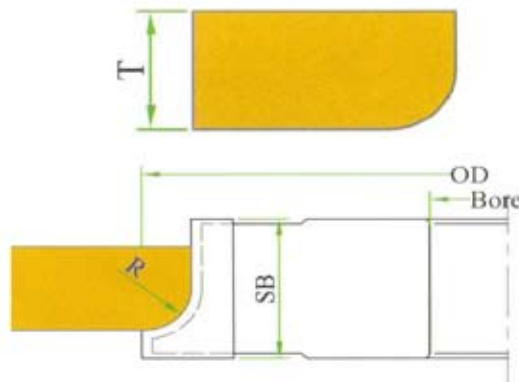
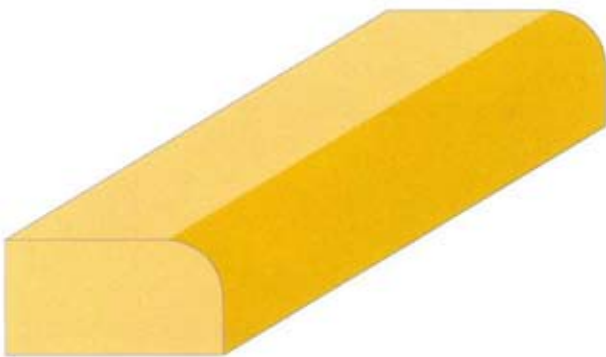

APPLICATION

For making quarter Radius in Post forming application

MACHINE

Spindle Moulder

WORK PIECE MATERIAL

Solid Wood
Uncoated Wood
Derived materials.

POST FORMING CUTTERS - HALF ROUND

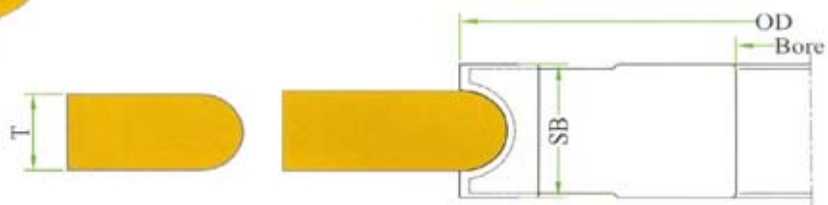
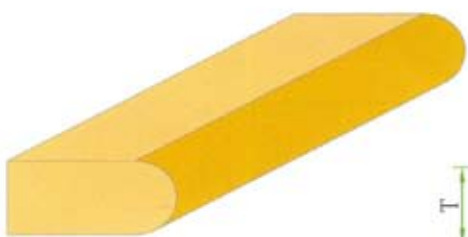

APPLICATION

For making Half Radius in Postforming application

MACHINE

Spindle Moulder

WORK PIECE MATERIAL

Solid Wood
Uncoated Wood
Derived materials.

POST FORMING CUTTERS - ELLIPTICAL PROFILE

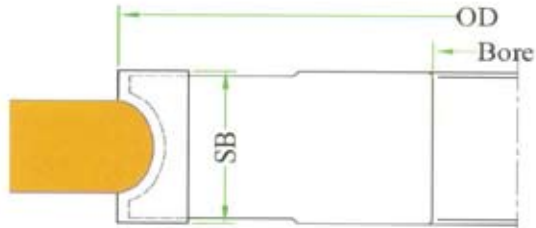
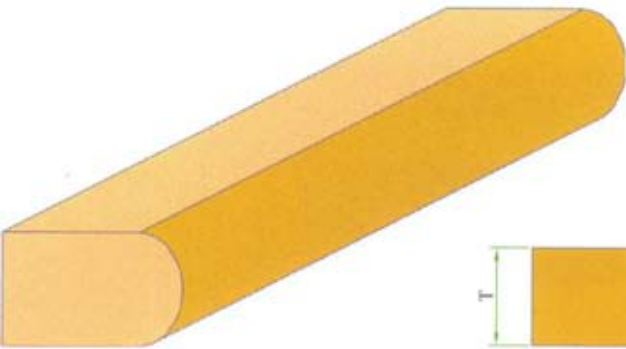

APPLICATION

Cutter for making Unique edge in joining of Half round Profile

MACHINE

Spindle Moulder

WORK PIECE MATERIAL

Solid Wood
Uncoated Wood
Derived materials.

POST FORMING CUTTERS - BULLNOSE PROFILE

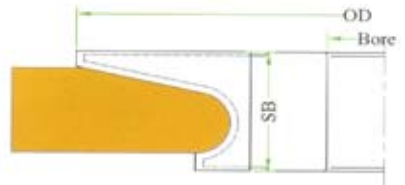
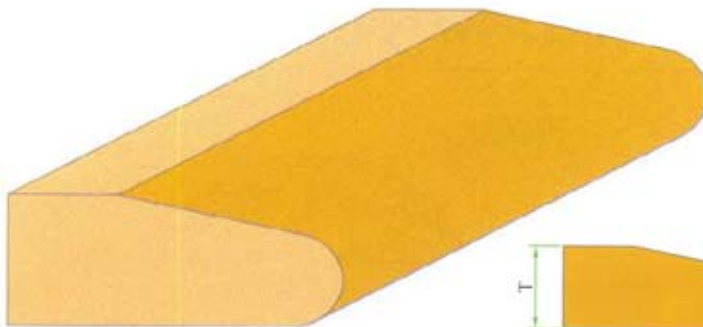

APPLICATION

Cutter for making Bull Nose Profiles on the Table top

MACHINE

Spindle Moulder

WORK PIECE MATERIAL

Solid Wood
Uncoated Wood
Derived materials.

DOVETAIL ROUTER CUTTER

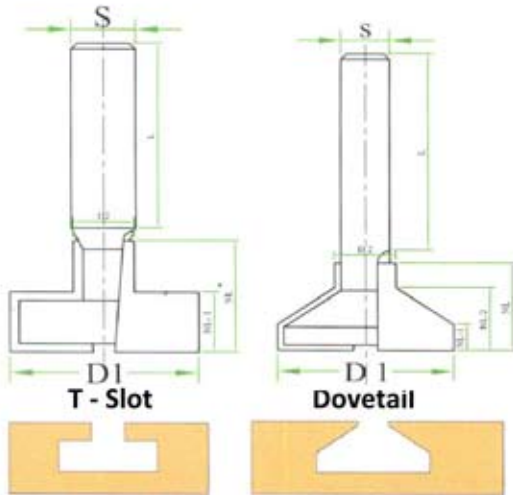

APPLICATION

For Dovetail & T-Slot Profile

MACHINE

Overhead Routers
with or without
CNC Control
Portable Routers

WORK PIECE MATERIAL

Solid Wood
Uncoated Veneered
Wood Derived materials.

PROFILE ROUTER CUTTER

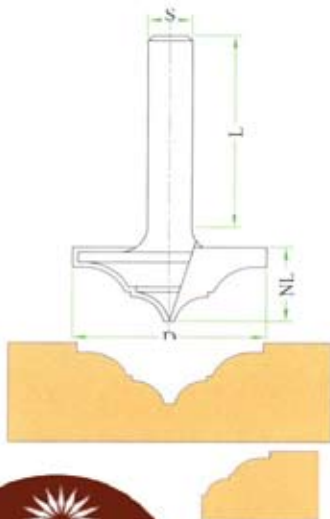

APPLICATION

For Profiling & Beading

MACHINE

Overhead Routers
with or without
CNC control
Portable Routers

WORK PIECE MATERIAL

Solid Wood
Uncoated Veneered
Wood Derived materials.



ARS & Co.,

PROFILE ROUTER CUTTER

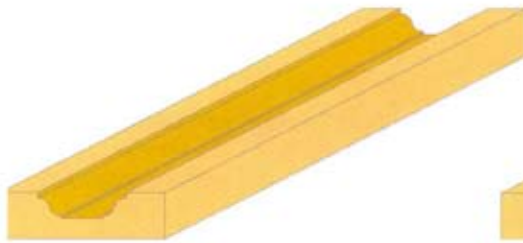
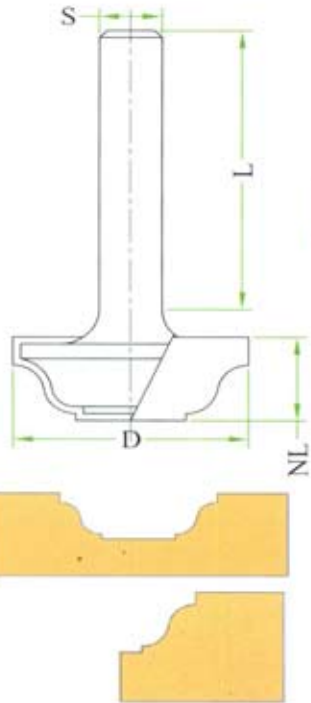

APPLICATION

Profiling

MACHINE

Overhead Routers
with or without
CNC Control

WORK PIECE MATERIAL

Solid Wood
Uncoated Veneered
Wood Derived materials.

PROFILE ROUTER CUTTER

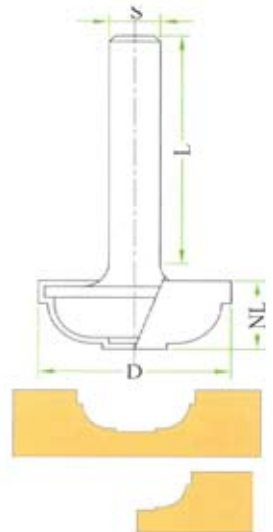
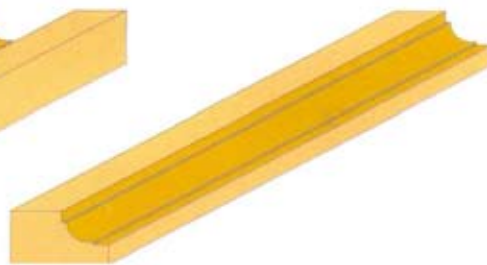
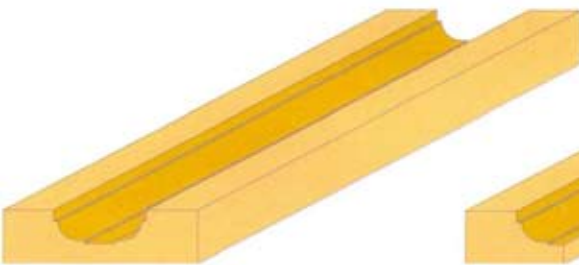

APPLICATION

Profiling

MACHINE

Overhead Routers
with or without
CNC control

WORK PIECE MATERIAL

Solid Wood
Uncoated Veneered
Wood Derived materials.

PROFILE ROUTER CUTTER

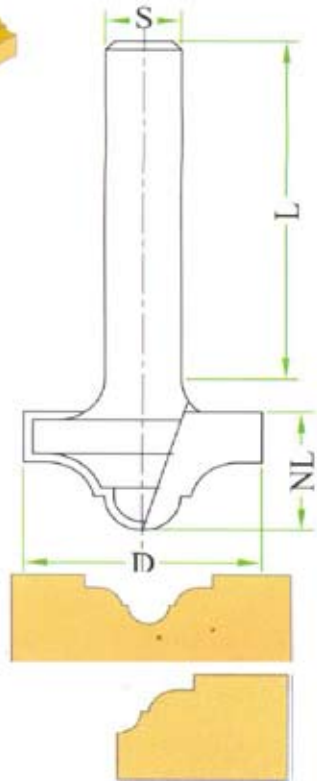
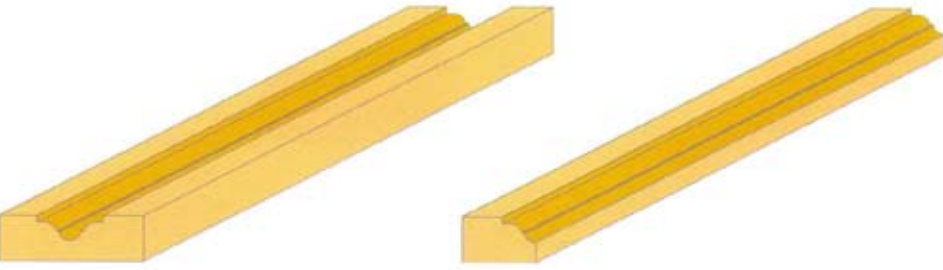

APPLICATION
Profiling

MACHINE
Overhead Routers
with or without
CNC Control

WORK PIECE MATERIAL
Solid Wood
Uncoated Veneered
Wood Derived materials.

PROFILE ROUTER CUTTER

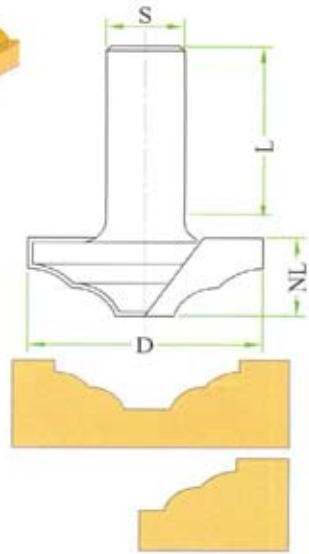
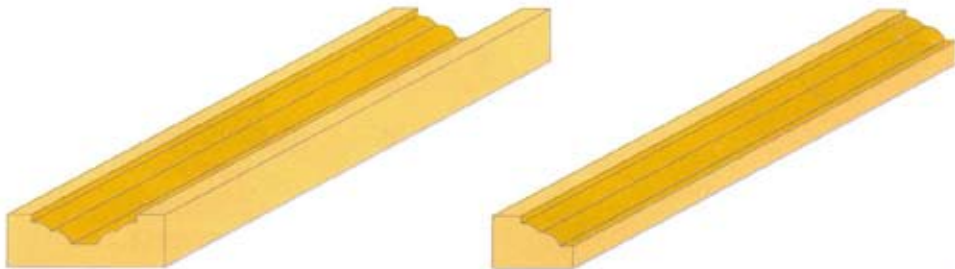

APPLICATION
For Profiling &
Beading

MACHINE
Overhead Routers
with or without
CNC control

WORK PIECE MATERIAL
Solid Wood
Uncoated Veneered
Wood Derived materials.



MDF PROFILE - ROUTERBITS (MEMBRANE PRESSING)

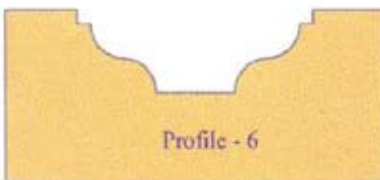
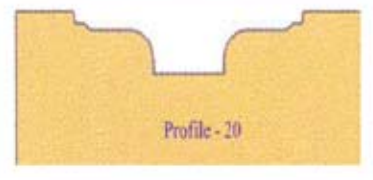
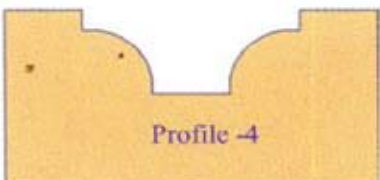
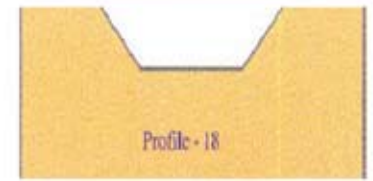
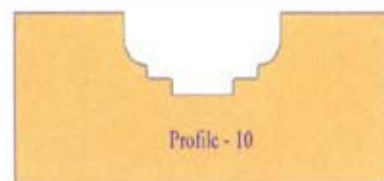
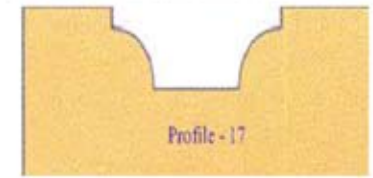
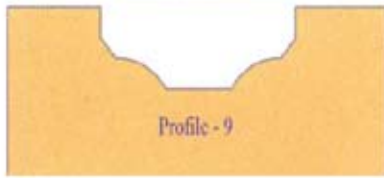

POST FORMING ROUTER CUTTER - HALF ROUND

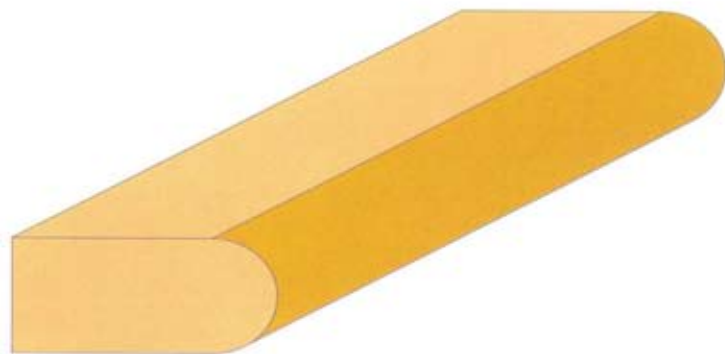

APPLICATION

For making Half Round
& Radius Profiles

MACHINE

Overhead Routers
with or without
CNC Control

WORK PIECE MATERIAL

Solid Wood
Uncoated Veneered
Wood Derived materials.

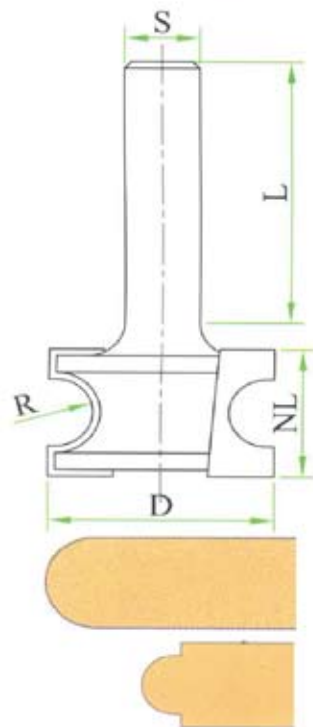

POST FORMING ROUTER CUTTERS - QUARTER ROUND

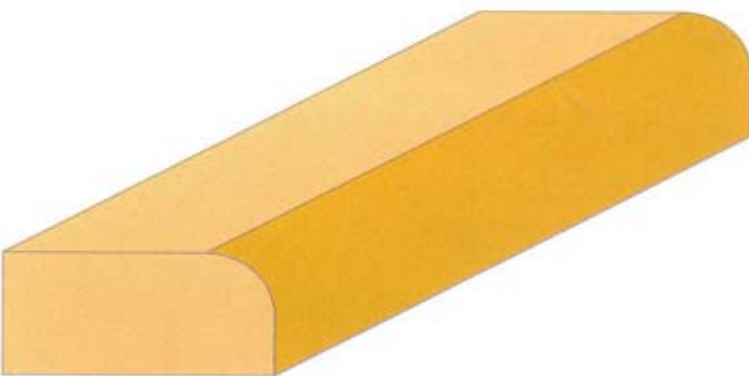

APPLICATION

For making Quarter Round
& Radius Profiles

MACHINE

Overhead Routers
with or without
CNC Control

WORK PIECE MATERIAL

Solid Wood
Uncoated Veneered
Wood Derived materials.

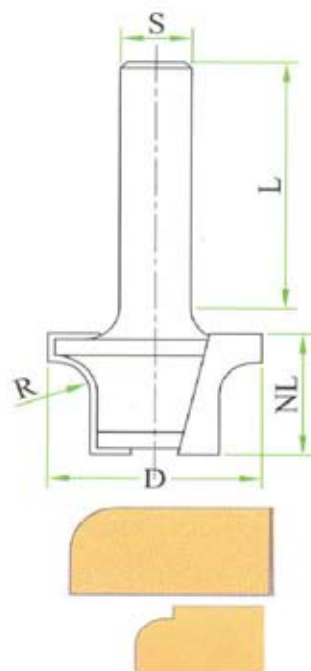

POST FORMING

ROUTER CUTTER - ELLIPTICAL PROFILE

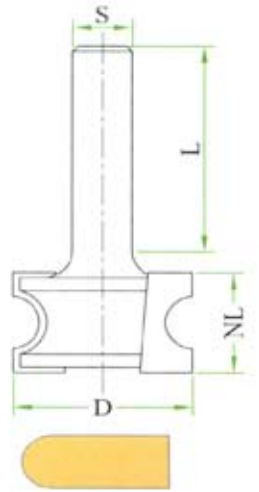
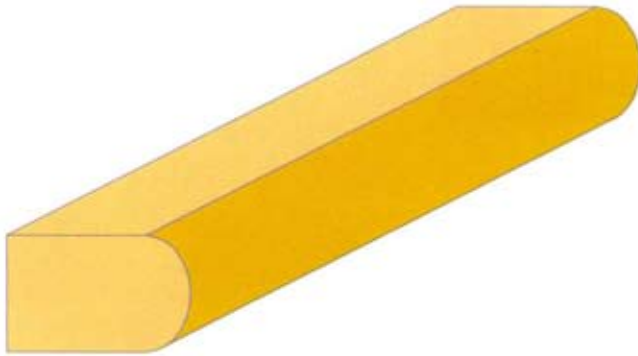

APPLICATION
For Elliptical Round
& Radius Profile

MACHINE
Overhead Routers
with or without
CNC Control

WORK PIECE MATERIAL
Solid Wood
Uncoated Veneered
Wood Derived materials.

POST FORMING ROUTER CUTTER - BULLNOSE PROFILE

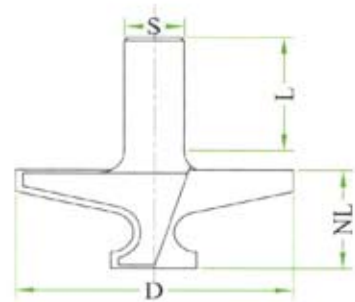
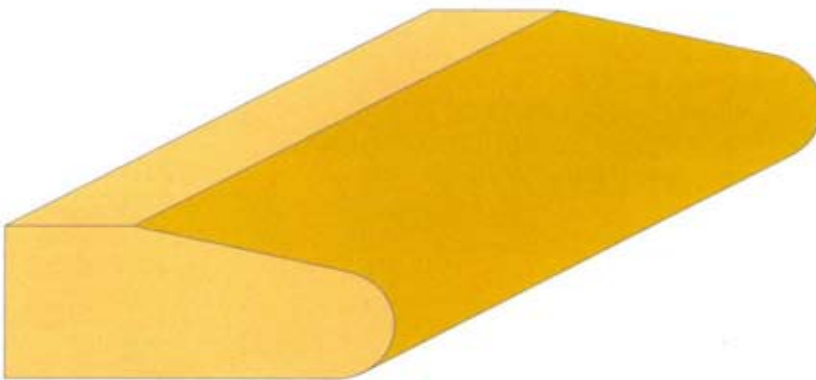

APPLICATION
For Bullnose Profile

MACHINE
Overhead Routers
with or without
CNC Control

WORK PIECE MATERIAL
Solid Wood
Uncoated Veneered
Wood Derived materials.

PCP CUTTERSET FOR CHOUKHAT (DOOR FRAME)

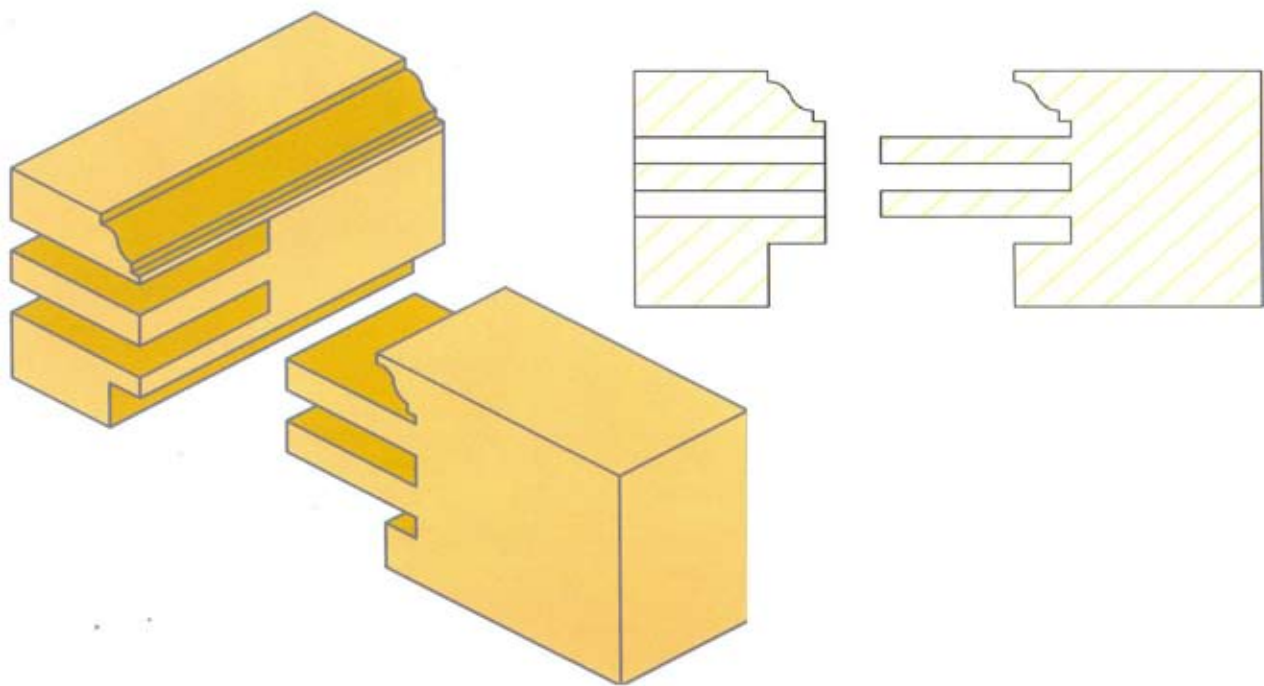

Can be provided on request
with / without Top Profile

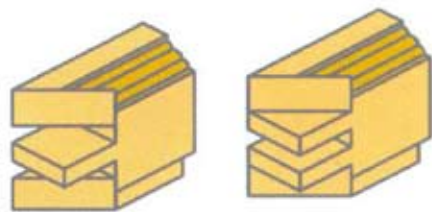

Mitre Joint

APPLICATION

Cutterset for making Choukhat
Profiles in different thickness range

MACHINE

Spindle Moulder,
Moulder,
Double end tenoner

WORK PIECE MATERIAL

Solid Wood

PROFILE / COUNTER PROFILE CUTTERSET FOR DOOR PROFILES

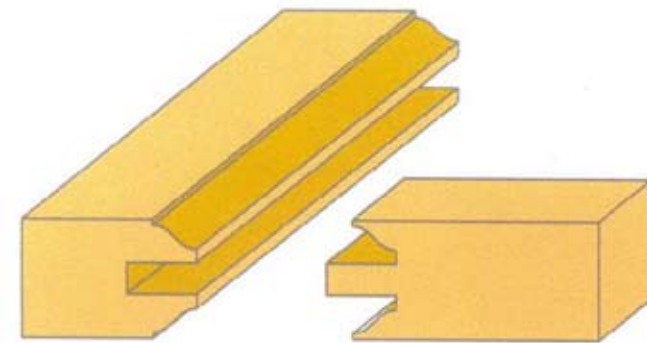

LIBRA

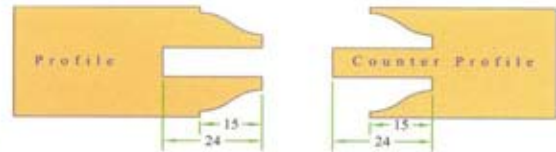

GEMINI



CAPRICORN



TAURUS



APPLICATION

Cutterset for Profile / Counter Profile for door frames.
Adjustable to suit 3 thickness ranges.

MACHINE

Spindle Moulder,
Moulder

WORK PIECE MATERIAL

Solid Wood

PROFILE / COUNTER PROFILE CUTTERSET FOR DOOR PROFILES - LONG TENNON DESIGN

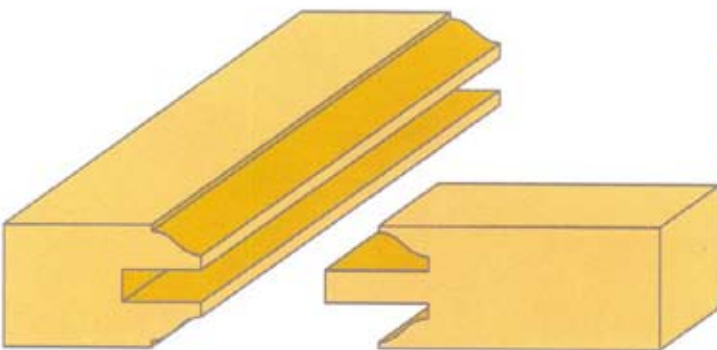

LIBRA

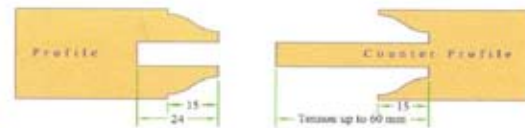

GEMINI



APRICORN



TAURUS

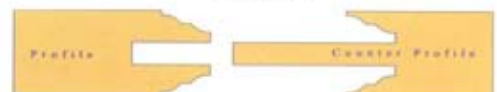

APPLICATION

Cutterset with long tenon for /
Counter Profile for frames.
Adjustable to suit 3 thickness ranges

MACHINE

Spindle Moulder,
Moulder

WORK PIECE MATERIAL

Solid Wood



ARS & Co.,

PANEL RAISING CUTTERS

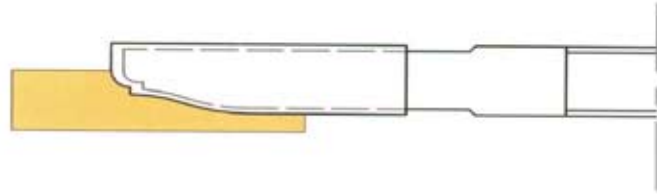

Radius Profile

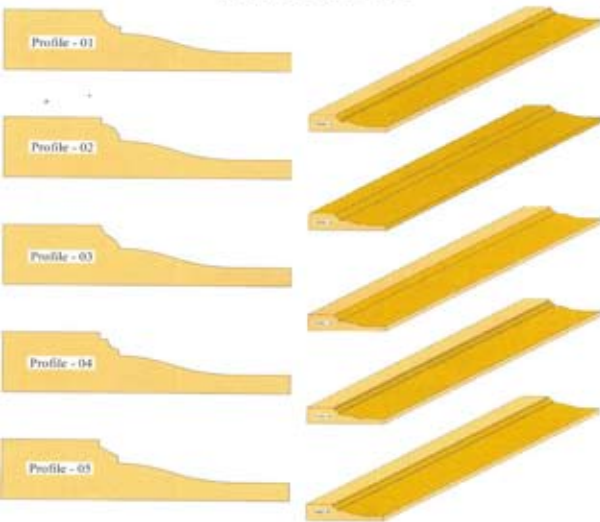

Angular Profile



APPLICATION

For making raised Panels for
Kitchen & Doors

MACHINE

Spindle Moulder,
Moulder

WORK PIECE MATERIAL

Solid Wood

PROFILE / COUNTER PROFILE ROUTER CUTTERSETS FOR MAKING DOOR PROFILES

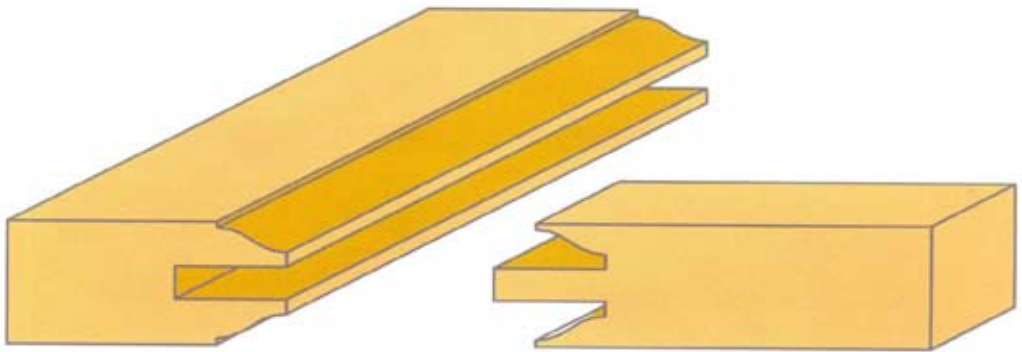
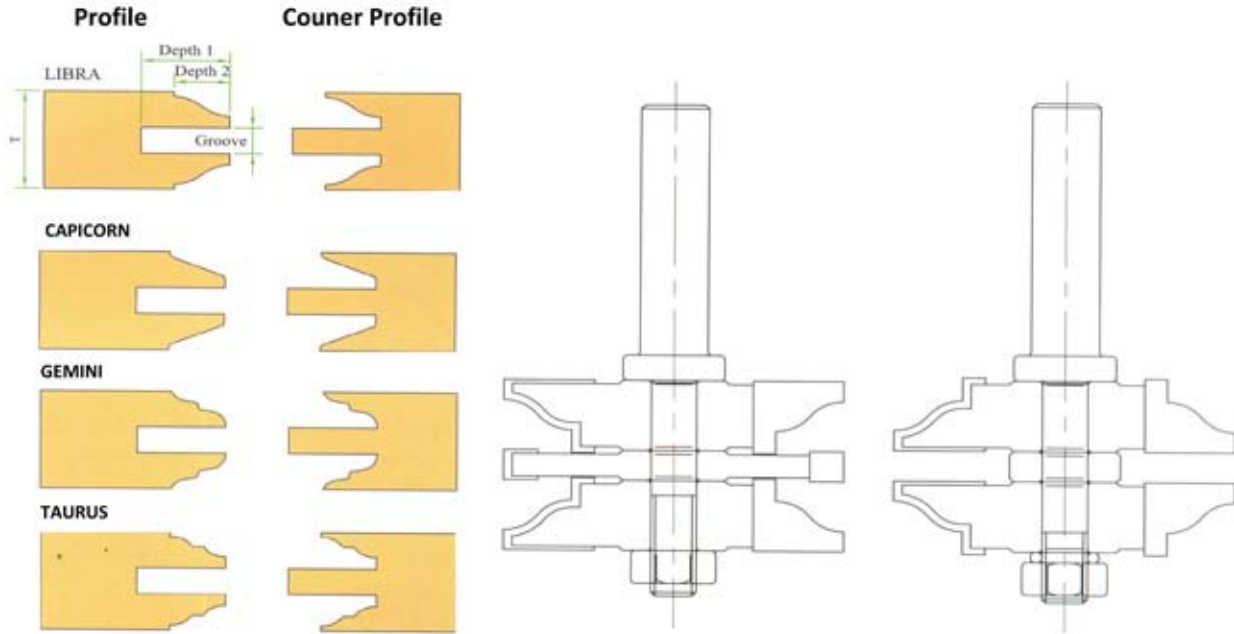

APPLICATION

Tool for making
Door frames

MACHINE

Overhead Routers
with or without
CNC Control

WORK PIECE MATERIAL

Solid Wood
Uncoated Veneered
Wood derived materials.

PANEL RAISING ROUTER CUTTER

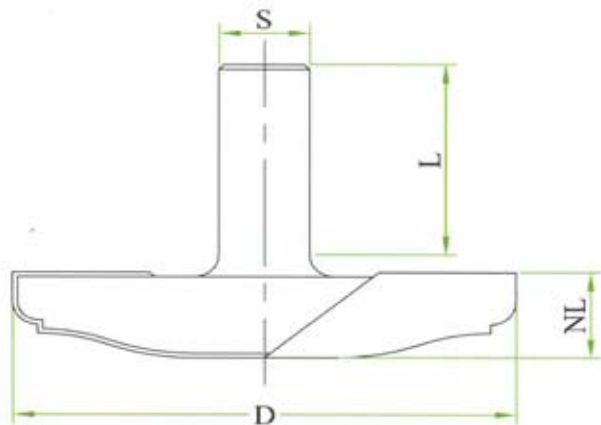

Radius Profile



Angular Profile



APPLICATION

For making raised Panels

MACHINE

Overhead Routers
with or without
CNC Control

WORK PIECE MATERIAL

Solid Wood
Uncoated Veneered
Wood derived materials.

PROFILE / COUNTER PROFILE CUTTERSETS FOR KITCHEN SHUTTERS & WARDROBES

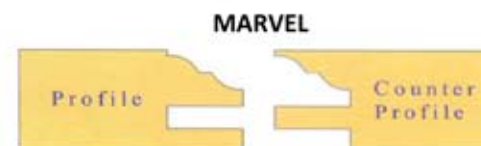
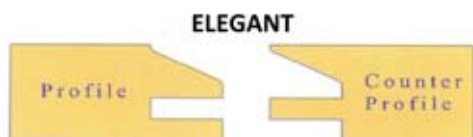
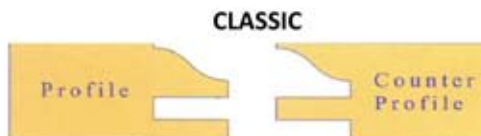
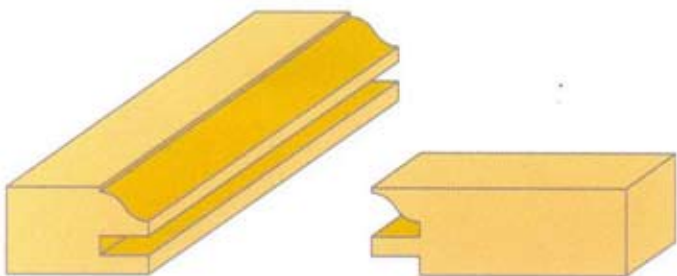

APPLICATION
Profile / Counter Profile
cutterset for making Solid wood
5 piece Kitchen Shutters & Wardrobes.
Adjustable to suit 3 thickness ranges.

MACHINE
Spindle Moulder, Solid Wood
Moulder

WORK PIECE MATERIAL

PROFILE / COUNTER PROFILE CUTTERSETS FOR WINDOW



NOTE: Combined cutter set for making kitchen Shutter, Wardrobe & Window can be provided on request.

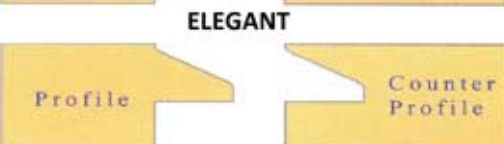
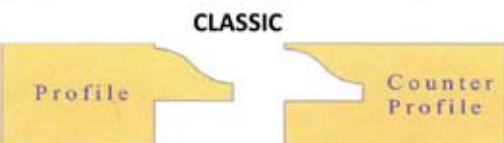

APPLICATION
Profile / Counter Profile
cutterset for making Solid wood
Window Profiles.

MACHINE
Spindle Moulder,
Moulder
WORK PIECE MATERIAL
Solid Wood

PROFILE / COUNTER PROFILE ROUTER CUTTER SETS FOR KITCHEN SHUTTERS, WARDROBES & WINDOWS

Profile

Counter Profile

CLASSIC

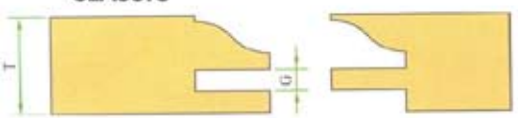

ELEGAN



EXCELLO



MARVEL

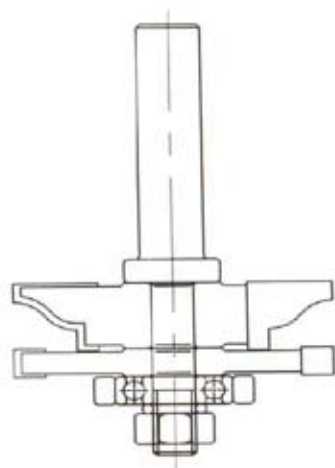

Profile

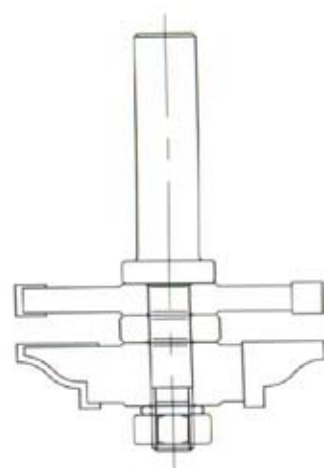

Counter Profile

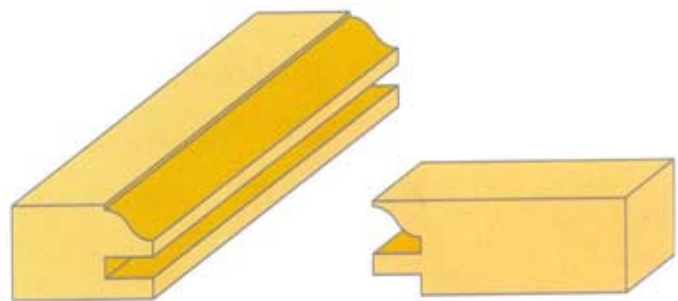

APPLICATION

5 Piece Kitchen Shutter,
Wardrobes & Windows
Profiles

MACHINE

Overhead Routers
with or without
CNC Control

WORK PIECE MATERIAL

Solid Wood
Uncoated Veneered
Wood derived materials.



ADJUSTABLE TONGUE AND GROOVE CUTTER SET FOR WOODEN FLOORING TILES



APPLICATION

Wooden flooring
tiles

MACHINE

Spindle Moulder,
Moulder,
Double end tenoner

WORK PIECE MATERIAL

Solid Wood